

Micro step 2-phase Stepper Motor Driver



MD2U-MD20 Series PRODUCT MANUAL

For your safety, read and follow the considerations written in the instruction manual, other manuals and Autonics website.

The specifications, dimensions, etc. are subject to change without notice for product improvement. Some models may be discontinued without notice.

Features

- Unipolar constant current drive method
- STOP current setting provides holding torque (brake function)
- Low vibration operation with micro stepping drive
- Isolated photocoupler input design minimizes influence from electrical noise
- Power supply Range: 24 - 35 VDC

Safety Considerations

- Observe all 'Safety Considerations' for safe and proper operation to avoid hazards.
- ⚠ symbol indicates caution due to special circumstances in which hazards may occur.

⚠ Warning Failure to follow instructions may result in serious injury or death.

- 01. Fail-safe device must be installed when using the unit with machinery that may cause serious injury or substantial economic loss. (e.g. nuclear power control, medical equipment, ships, vehicles, railways, aircraft, combustion apparatus, safety equipment, crime / disaster prevention devices, etc.)**
Failure to follow this instruction may result in personal injury, economic loss or fire.
- 02. Do not use the unit in the place where flammable / explosive / corrosive gas, high humidity, direct sunlight, radiant heat, vibration, impact or salinity may be present.**
Failure to follow this instruction may result in explosion or fire.
- 03. Do not connect, repair, or inspect the unit while connected to a power source.**
Failure to follow this instruction may result in fire or electric shock.
- 04. Install the unit after considering counter plan against power failure.**
Failure to follow this instruction may result in personal injury, economic loss or fire.
- 05. Check 'Connections' before wiring.**
Failure to follow this instruction may result in fire.
- 06. Do not disassemble or modify the unit.**
Failure to follow this instruction may result in fire.
- 07. Install the driver in the housing or ground it.**
Failure to follow this instruction may result in personal injury, fire or electronic shock.
- 08. Do not touch the unit during or after operation for a while.**
Failure to follow this instruction may result in burn or electric shock due to high temperature of the surface.
- 09. For rotating the motor manually when turning off the power, separate the motor and the driver.**
Failure to follow this instruction may result in malfunction due to power applied to the driver.
- 10. Emergency stop directly when error occurs.**
Failure to follow this instruction may result in personal injury or fire.

⚠ Caution Failure to follow instructions may result in injury or product damage.

- 01. When connecting the power input, use AWG18 (0.75 mm²) cable or over.**
- 02. Install over-current prevention device (e.g. the current breaker, etc.) to connect the driver with power.**
Failure to follow this instruction may result in fire.
- 03. Check the control input signal before supplying power to the driver.**
Failure to follow this instruction may result in personal injury or product damage by unexpected driver movement.
- 04. Install a safety device to maintain the vertical position after turn off the power of this driver.**
Failure to follow this instruction may result in personal injury or product damage by releasing holding torque of the motor.
- 05. Use the unit within the rated specifications.**
Failure to follow this instruction may result in fire or product damage.
- 06. Use a dry cloth to clean the unit, and do not use water or organic solvent.**
Failure to follow this instruction may result in fire or electric shock.
- 07. The driver may overheat depending on the environment.**
Install the unit at the well-ventilated environment and forced cooling with a cooling fan.
Failure to follow this instruction may result in product damage or degradation by heat.
- 08. Keep the product away from metal chip, dust, and wire residue which flow into the unit.**
Failure to follow this instruction may result in fire or product damage.
- 09. Use the designated motor only.**
Failure to follow this instruction may result in fire or product damage.

Cautions during Use

- Follow instructions in 'Cautions during Use'. Otherwise, it may cause unexpected accidents.
- Power supply should be insulated and limited voltage/current or Class 2, SELV power supply device.
- Re-supply power after 1 sec from disconnected power.
- When the signal input voltage is exceeded the rated voltage, connect additional resistance at the outside.
- Set RUN current within the range of motor's rated current depending on the load. When the rated motor current is exceeded, the heat may increase and motor may be damaged.
- If the driver stops by the current down function, switches to STOP current. If the current down function is not set or HOLD OFF signal is [H], STOP current switching will not be executed.
- Use twisted pair (over 0.2 mm²) for the signal cable within 2 m.
- In case of extending the motor cable, use the cable that is thicker than lead cable.
- Keep the distance between power cable and signal cable over 10 cm.
- If the power is supplied while TEST switch is ON, the motor operates immediately and it may be dangerous.
- Do not change any setting switches (function selection, RUN/STOP current, resolution) during the operation or after supplying power. Failure to follow this instruction may result in malfunction.
- Motor vibration and noise may occur in a specific frequency range.
 - Change the motor installation method or attach the damper.
 - Use the unit out of the corresponding frequency range due to changing motor RUN speed.
- Maintain and inspect regularly the following lists.
 - Unwinding bolts and connection parts for the unit installation and load connection
 - Abnormal sound from ball-bearing of the unit
 - Damage and stress of lead cable of the unit
 - Connection error with motor
 - Inconsistency between the axis of motor output and the center, concentric (eccentric, declination) of the load, etc.
- This product does not contain a protection function for a motor unit.
- This unit may be used in the following environments.
 - Indoors (in the environment condition rated in 'Specifications')
 - Altitude max. 2,000 m
 - Pollution degree 2
 - Installation category II

Product Components

- Product
- Instruction manual

Dimensions

- Unit: mm, For the detailed drawings, follow the Autonics website.

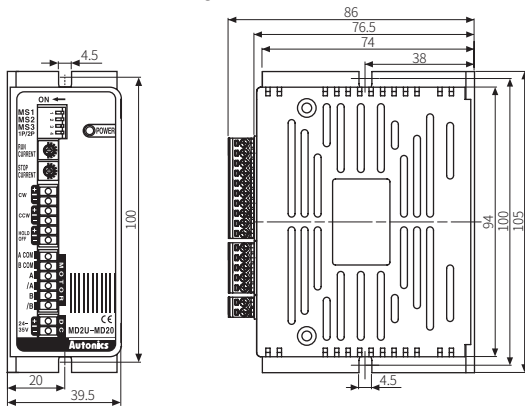

Specifications

Model	MD2U-MD20
Power supply ⁰¹⁾	24 - 35 VDC≐
Permissible voltage range	90 to 110% of rated voltage
Max. current consumption	3 A (based on ambient temp. 25°C, ambient humi. 55%RH)
RUN current ⁰²⁾	0.5 - 2 A / Phase
STOP current	20 to 70% of RUN current (set by stop current setting rotary switch)
RUN method	Unipolar constant current drive
Basic step angle	1.8° / Step
Resolution	1, 2, 4, 5, 8, 10, 16, 20 division (1.8° to 0.09° / Step)
Pulse width	≥ 10 μs (CW / CCW), 1 ms (HOLD OFF)
Duty rate	50% (CW / CCW)
Rise, Fall time	≤ 0.5 μs (CW / CCW)
Pulse input voltage	[H]: 4 - 8 VDC≐, [L]: 0 - 0.5 VDC≐
Pulse input current	4 mA (CW / CCW), 10 mA (HOLD OFF)
Max. input pulse frequency	≤ 50 kHz (CW / CCW)
Input resistance	300 Ω (CW / CCW), 390 Ω (HOLD OFF)
Insulation resistance	Between the charging part and the case: ≥ 200 MΩ (500 VDC≐ megger)
Dielectric strength	Between the charging part and the case: 1,000 VAC ~ 50 / 60 Hz for 1 min
Noise immunity	± 500 VDC≐ square wave noise (pulse width: 1 μs) by the noise simulator
Vibration	1.5 mm double amplitude at frequency 10 to 55 Hz in each X, Y, Z direction for 2 hours
Shock	300 m/s ² (≈ 30 G) in each X, Y, Z direction for 3 times
Ambient temp.	0 to 50°C, storage: -10 to 60°C (no freezing or condensation)
Ambient humi.	35 to 85% RH, storage: 35 to 85% RH (no freezing or condensation)
Certification	CE, ENEC
Unit weight (packaged)	≈ 180 g (≈ 295 g)

- 01) If a power supply is over 30 VDC≐, the torque characteristics in the high speed range will improve, but the driver's temperature will increase as well. Install the unit in well-ventilated area. The torque may vary depending on power supply.
- 02) RUN current varies depending on the RUN frequency, and the max. instantaneous RUN current varies depending on load.

Function Setting

Function selection DIP switch

No.	Name	Function	Description
1	MS1	Micro step setting	It sets the step angle (rotation angle for 1 pulse). Set step angle = $\frac{\text{Step angle (1.8°)}}{\text{Resolution}}$ The setting must be changed when the motor stops.
2	MS2		
3	MS3		
4	1P/2P	Pulse input method	[ON: 1 pulse input method, OFF: 2 pulse input method] 1 pulse input method: CW → Operating rotation signal input CCW → Rotation direction signal input ([H]: Forward rotation, [L]: Reverse rotation) 2 pulse input method: CW → Forward rotation signal input CCW → Reverse rotation signal input

- For micro stepping setting, refer the table as follows.

MS1	MS2	MS3	Resolution
ON	ON	ON	1 division (Full step)
ON	ON	OFF	2 division
ON	OFF	ON	4 division
ON	OFF	OFF	5 division
OFF	ON	ON	8 division
OFF	ON	OFF	10 division
OFF	OFF	ON	16 division
OFF	OFF	OFF	20 division

RUN current

RUN CURRENT

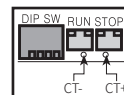
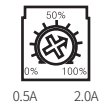

- It is able to set the RUN current of the motor.
- When RUN current is increased, RUN torque of the motor is also increased.
- When RUN current is increased, the heat of the motor is also increased.
- Set RUN current for the load within range of the rated current of the motor.
- RUN current setting range: 0.5 - 2.0 A
- RUN current setting method: measure the voltage by connecting a DC voltage meter to both CT+ and CT- terminals while the motor is running (max. 150 rpm)

$$\text{E.g.) Input voltage (3V)} \times \frac{2}{3} = 2\text{A (Motor Excitation Current)}$$

- The setting must be changed when the motor stops.

Stop current

STOP CURRENT

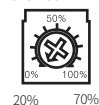

- It is able to set the current provided to the motor in stop status, and reduce the heat of the motor.
- It is set through the variable resistance ratio within 0 to 100% of RUN current setting range (actual setting range: 20 to 70%)
E.g.) If the RUN current is 2 A, STOP current setting is 0% (actual setting value: 20%), the STOP current is 2 A × 0.2 = 0.4 A.
- Depending on the winding impedance of the motor, the STOP current may have an error.
- When STOP current is increased, RUN torque of the motor is also increased.
- When RUN current is increased, the heat of the motor is also increased.
- The setting must be changed when the motor stops.

HOLD OFF

- This signal is for rotating motor shaft with external force or manual positioning.
 - When HOLD OFF signal remains over 1 ms as [H], motor excitation is released.
 - When HOLD OFF signal remains over 1 ms as [L], motor excitation is in normal status.
- Refer to 'I/O Circuit and Connections'.
- The setting must be changed when the motor stops.

Timing Chart

- The rotation direction is based on facing the shaft, and it is clockwise (CW) when rotating to the right.

1 pulse input method

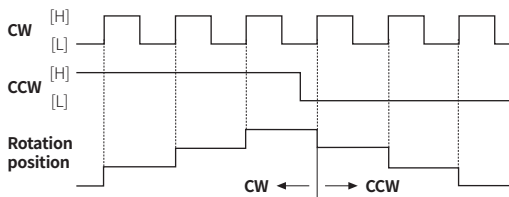

2 pulse input method

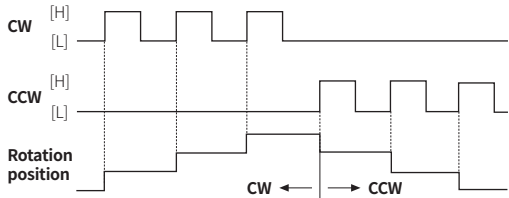

- Do not input CW, CCW signal at the same time in 2 pulse input method. It may not operate properly if either of the signal is [H] and another direction signal is input.

I/O Circuit and Connections

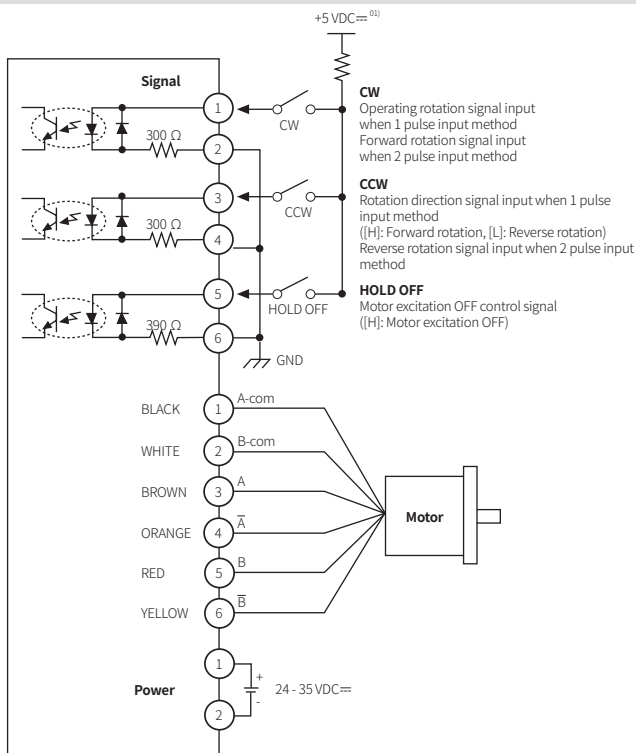

01) If the external signal input voltage is exceed the +5 VDC \approx , connect a resistor at outside. (Input voltage max. 24 VDC \approx , input current 10 - 20mA)

Ordering Information

This is only for reference, the actual product does not support all combinations. For selecting the specified model, follow the Autonics website.

MD ① ② - ③ ④ ⑤

- ① Motor phase**
2: 2-phase
- ② Operation method**
U: Unipolar drive
- ③ Step method (resolution)**
M: Micro step (20-division)
- ④ Power supply**
D: 24 - 35 VDC
- ⑤ RUN current**
20: 2 A/Phase

Unit Descriptions

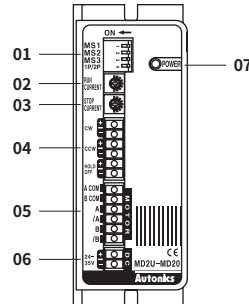

- 01. Function selection DIP switch
- 02. RUN current setting rotary switch
- 03. Stop current setting rotary switch
- 04. Input terminal
- 05. Motor terminal
- 06. Power terminal
- 07. Power indicator

Troubleshooting

Malfunction	Troubleshooting
When motor does not excite	Check the connection status between controller and driver and pulse input specifications (voltage, width). Check the pulse and direction signal are connected correctly.
When motor rotates to the opposite direction of the designated direction	When the driver's RUN mode is 1-pulse input method, CCW input [H] is for forward, [L] is for backward. When the driver's RUN mode is 2-pulse input method, check CW and CCW pulse input are changed.
When motor drives unstable	Check the driver and motor are connected correctly. Check the driver pulse input specifications (voltage, width).