

Micro step 5-phase Stepper Motor Driver

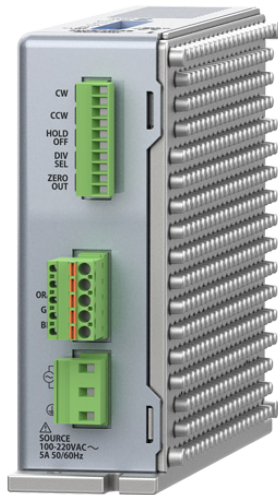

MD5-HF28 Series PRODUCT MANUAL

For your safety, read and follow the considerations written in the instruction manual, other manuals and Autonics website.

The specifications, dimensions, etc. are subject to change without notice for product improvement. Some models may be discontinued without notice.

Features

- Bipolar constant current pentagon drive method
- Various built-in functions including auto current down and self-diagnosis
- Low speed rotation and extreme precision control with micro stepping drive (Max. resolution is 250 divisions. In case of 5 phase stepper motor with 0.72° basic step angle, it can be controlled down to 0.00288° per pulse, 125000 pulses are required for a single revolution.)
- Isolated photocoupler input design minimizes influence from electrical noise

Safety Considerations

- Observe all 'Safety Considerations' for safe and proper operation to avoid hazards.
- ⚠ symbol indicates caution due to special circumstances in which hazards may occur.

⚠ Warning Failure to follow instructions may result in serious injury or death.

- 01. Fail-safe device must be installed when using the unit with machinery that may cause serious injury or substantial economic loss. (e.g. nuclear power control, medical equipment, ships, vehicles, railways, aircraft, combustion apparatus, safety equipment, crime / disaster prevention devices, etc.)**
Failure to follow this instruction may result in personal injury, economic loss or fire.
- 02. Do not use the unit in the place where flammable / explosive / corrosive gas, high humidity, direct sunlight, radiant heat, vibration, impact or salinity may be present.**
Failure to follow this instruction may result in explosion or fire.
- 03. Do not connect, repair, or inspect the unit while connected to a power source.**
Failure to follow this instruction may result in fire or electric shock.
- 04. Install the unit after considering counter plan against power failure.**
Failure to follow this instruction may result in personal injury, economic loss or fire.
- 05. Check 'Connections' before wiring.**
Failure to follow this instruction may result in fire.
- 06. For installing the unit, ground it exclusively and use over AWG 18 (0.75 mm²) ground cable.**
Failure to follow this instruction may result in electric shock.
- 07. Do not disassemble or modify the unit.**
Failure to follow this instruction may result in fire.
- 08. Insulate the connector not to be exposed.**
Failure to follow this instruction may result in electric shock.
- 09. Install the driver in the housing or ground it.**
Failure to follow this instruction may result in personal injury, fire or electronic shock.
- 10. Do not touch the unit during or after operation for a while.**
Failure to follow this instruction may result in burn or electric shock due to high temperature of the surface.
- 11. Emergency stop directly when error occurs.**
Failure to follow this instruction may result in personal injury or fire.

⚠ Caution Failure to follow instructions may result in injury or product damage.

- 01. When connecting the power input, use AWG18 (0.75 mm²) cable or over.**
- 02. Install over-current prevention device (e.g. the current breaker, etc.) to connect the driver with power.**
Failure to follow this instruction may result in fire.
- 03. Check the control input signal before supplying power to the driver.**
Failure to follow this instruction may result in personal injury or product damage by unexpected driver movement.
- 04. Install a safety device to maintain the vertical position after turn off the power of this driver.**
Failure to follow this instruction may result in personal injury or product damage by releasing holding torque of the motor.
- 05. Use the unit within the rated specifications.**
Failure to follow this instruction may result in fire or product damage.
- 06. Use a dry cloth to clean the unit, and do not use water or organic solvent.**
Failure to follow this instruction may result in fire or electric shock.
- 07. The driver may overheat depending on the environment.**
Install the unit at the well-ventilated environment and forced cooling with a cooling fan.
Failure to follow this instruction may result in product damage or degradation by heat.
- 08. Keep the product away from metal chip, dust, and wire residue which flow into the unit.**
Failure to follow this instruction may result in fire or product damage.
- 09. Use the designated motor only.**
Failure to follow this instruction may result in fire or product damage.

Cautions during Use

- Follow instructions in 'Cautions during Use'.
Otherwise, it may cause unexpected accidents.
- Re-supply power after 1 sec from disconnected power.
- Do not input CW, CCW signal at the same time in 2 pulse input method.
- When the signal input voltage is exceeded the rated voltage, connect additional resistance at the outside.
- Set RUN current within the range of motor's rated current depending on the load.
When the rated motor current is exceeded, the heat may be increased and motor may be damaged.

- If the driver stops by the current down function, switches to STOP current.
If the current down function is not set or HOLD OFF signal is [H], STOP current switching will not be executed.
- Use twisted pair (over 0.2 mm²) for the signal cable within 2 m.
- In case of extending the motor cable, use the cable that is thicker than lead cable.
- Keep the distance between power cable and signal cable over 10 cm.
- For heat radiation of the driver, install a fan as follows.
(A: install within 70 mm between fan and driver, B: min. airflow 0.71 mm³ / min)

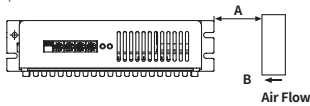

- If the power is supplied while TEST switch is ON, the motor operates immediately and it may be dangerous.
- Do not change any setting switches (function selection, RUN/STOP current, resolution) during the operation or after supplying power. Failure to follow this instruction may result in malfunction.
- Motor vibration and noise may occur in a specific frequency range.
 - Change the motor installation method or attach the damper.
 - Use the unit out of the corresponding frequency range due to changing motor RUN speed.
- Maintain and inspect regularly the following lists.
 - Unwinding bolts and connection parts for the unit installation and load connection
 - Abnormal sound from ball-bearing of the unit
 - Damage and stress of lead cable of the unit
 - Connection error with motor
 - Inconsistency between the axis of motor output and the center, concentric (eccentric, declination) of the load, etc.
- This product does not contain a protection function for a motor unit.
- This unit may be used in the following environments.
 - Indoors (in the environment condition rated in 'Specifications')
 - Altitude max. 2,000 m
 - Pollution degree 2
 - Installation category II

Dimensions

- Unit: mm, For the detailed drawings, follow the Autonics website.

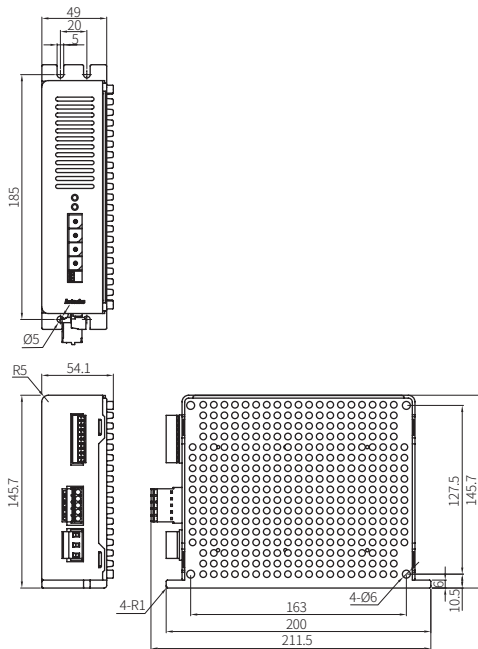

Specifications

Model	MD5-HF28
Power supply	100 - 220 VAC ~ 50 / 60 Hz
Permissible voltage range	90 to 110% of rated voltage
Max. current consumption	5 A (based on ambient temp. 25°C, ambient humi. 55%RH)
RUN current⁰¹⁾	1.0 - 2.8 A / Phase
Stop current	27 to 90% of RUN current (set by STOP current setting rotary switch)
RUN method	Bipolar constant current pentagon drive
Basic step angle	0.72° / Step
Resolution	1, 2, 4, 5, 8, 10, 16, 20, 25, 40, 50, 80, 100, 125, 200, 250 division (0.72° to 0.00288° / Step)
Pulse width	≥ 1 μs (CW / CCW), ≥ 1 ms (HOLD OFF)
Duty rate	50% (CW / CCW)
Rise, Fall time	≤ 130 ns (CW / CCW)
Pulse input voltage	[H]: 4 - 8 VDC =, [L]: 0 - 0.5 VDC =
Pulse input current	7.5 - 14 mA (CW / CCW), 10 - 16 mA (HOLD OFF, DIVISION SELECTION, ZERO OUT)
Max. input pulse freq.	≤ 500 kHz (CW / CCW)
Input resistance	270 Ω (CW / CCW), 390 Ω (HOLD OFF, DIVISION SELECTION), 10 Ω (ZERO OUT)
Insulation resistance	Between the charging part and the case: ≥ 100 MΩ (500 VDC = megger)
Dielectric strength	Between the charging part and the case: 1,000 VAC ~ 50 / 60 Hz for 1 min ± 2000 VDC = square wave noise (pulse width: 1 μs) by the noise simulator
Noise immunity	1.5 mm double amplitude at frequency 5 to 60 Hz in each X, Y, Z direction for 2 hours
Vibration	1.5 mm double amplitude at frequency 5 to 60 Hz in each X, Y, Z direction for 10 minutes
Vibration (malfunction)	1.5 mm double amplitude at frequency 5 to 60 Hz in each X, Y, Z direction for 10 minutes
Ambient temp.	0 to 50°C, storage: -10 to 60°C (no freezing or condensation)
Ambient humi.	35 to 85% RH, storage: 35 to 85% RH (no freezing or condensation)
Certification	CE, RoHS, REACH, UL
Unit weight (packaged)	≈ 1.2 kg (≈ 1.35 kg)

⁰¹⁾ RUN current varies depending on the RUN frequency, and the max. instantaneous RUN current varies depending on load.

Product Components

- Product
- Instruction manual

Function Setting

Function selection DIP switch

No.	Name	Function	Description
1	TEST	Self diagnosis function	[ON: 250 pps rotation, OFF: Disable] It rotates 30 rpm in full step, rotation speed may vary according to resolution setting. Rotation speed = $\frac{30 \text{ rpm}}{\text{Resolution}}$ In 1 pulse input method, it rotates to CCW and in 2 pulse input method, it rotates to CW. The setting must be changed when the motor stops.
2	1/2 CLK	Pulse input method	[ON: 1 pulse input method, OFF: 2 pulse input method] 1 pulse input method: CW → Operating rotation signal input CCW → Rotation direction signal input ([H]: Forward rotation, [L]: Reverse rotation) 2 pulse input method: CW → Forward rotation signal input CCW → Reverse rotation signal input
3	C/D	Auto current down	[ON: Disable, OFF: Enable] This function allows to reduce the current provided to motor automatically for preventing severe motor heat while motor stops. If motor RUN pulse is not applied, the current provided to motor reduces as set STOP current.

RUN current

Setting	0	1	2	3	4	5	6	7	8	9	A	B	C	D	E	F
Current (A / Phase)	1.14	1.25	1.36	1.50	1.63	1.74	1.86	1.97	2.10	2.20	2.30	2.40	2.50	2.60	2.78	2.88

- It is able to set the RUN current of the motor.
- When RUN current is increased, RUN torque of the motor is also increased.
- When RUN current is increased, the heat of the motor is also increased.
- Set RUN current for the load within range of the rated current of the motor.
- The setting must be changed when the motor stops.

Stop current

Setting	0	1	2	3	4	5	6	7	8	9	A	B	C	D	E	F
%	27	31	36	40	45	50	54	58	62	66	70	74	78	82	86	90

- This function allows to control the current provided to motor for preventing severe motor heat while motor stops.
- The setting is applied when using C/D (Current Down) function.
- STOP current setting value is % ratio of set RUN current.
E.g.) If the RUN current is 1.4 A, STOP current setting is 40%, the STOP current is 1.4 A × 0.4 = 0.56 A.
- When STOP current is increased, RUN torque of the motor is also increased.
- When RUN current is increased, the heat of the motor is also increased.
- The setting must be changed when the motor stops.

Micro step setting (Micro step: Resolution)

Setting	0	1	2	3	4	5	6	7	8	9	A	B	C	D	E	F
Resolution	1	2	4	5	8	10	16	20	25	40	50	80	100	125	200	250
Step angle (°)	0.72	0.36	0.18	0.144	0.09	0.072	0.045	0.036	0.0288	0.018	0.0144	0.009	0.0072	0.00576	0.0036	0.00288

- Two resolutions can be set with MS1, MS2 switch.
- MS1 or MS2 can be selected with DIVISION SELECTION signal. ([L]: MS1, [H]: MS2)
- It sets the step angle (rotation angle for 1 pulse).
- The set step angle is divided angle with set revolution by setting basic step angle of 0.72
- The set step angle is the angle divided by the set resolution of 0.72° basic step angle of 5-phase stepper motor.
- The divided step angle is based on following equation.
Set step angle = $\frac{\text{Basic step angle (0.72°)}}{\text{Resolution}}$
- In case of using built-in gear motor, the step angle is applied the angle divided by reduction ratio.
 $\frac{\text{Step angle}}{\text{Reduction ratio}} = \text{Step angle applied by gear}$ E.g.) $\frac{0.72°}{10 (1:10)} = 0.072°$
- The setting must be changed when the motor stops.

Zero point excitation output signal (ZERO OUT)

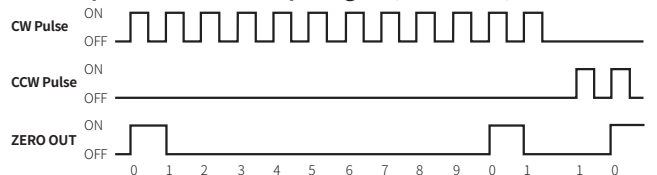

- This output indicates the beginning of the stepper motor excitation sequence, and allows to know the rotational position of the motor shaft.
- Regardless of the resolution, the pulse is output every 7.2° rotation of motor shaft. (50 outputs per motor rotation)
E.g.) Full step: 1 output for 10 input pulse, 20 division: 1 output for 200 input pulse

HOLD OFF

- This signal is for rotating motor shaft with external force or manual positioning.
 - When HOLD OFF signal remains over 1 ms as [H], motor excitation is released.
 - When HOLD OFF signal remains over 1 ms as [L], motor excitation is in normal status.
- Refer to 'I/O Circuit and Connections'.
- The setting must be changed when the motor stops.

Alarm indicator function

- Overheat**
When the driver temperature is over 80°C, the alarm indicator turns ON and the motor stops with remaining torque. Alarm indicator will turn OFF when re-supply power after turn OFF power and remove the causes.
- Overcurrent**
When overcurrent occurs due to motor damage by burn, internal damage or an abnormal alarm, the alarm indicator will flash. Alarm indicator will turn OFF when re-supply power after turn OFF power and remove the causes.

Timing Chart

- The rotation direction is based on facing the shaft, and it is clockwise (CW) when rotating to the right.

1 pulse input method

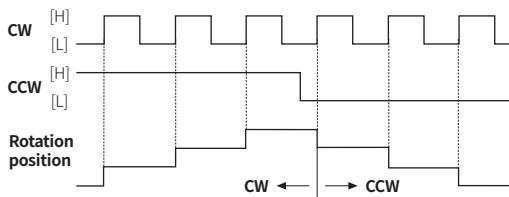

2 pulse input method

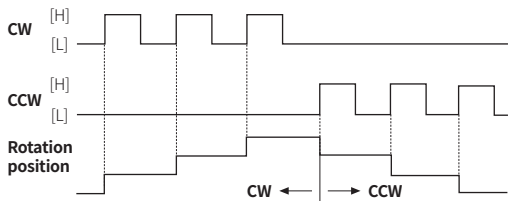

- Do not input CW, CCW signal at the same time in 2 pulse input method. It may not operate properly if either of the signal is [H] and another direction signal is input.

I/O Circuit and Connections

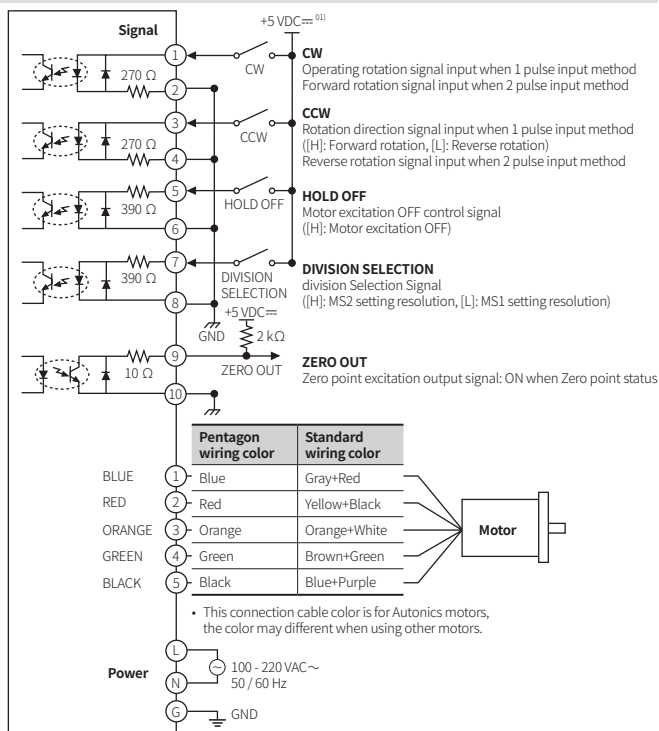

01) If the external signal input voltage is exceed the +5 VDC, connect a resistor at outside.

Troubleshooting

Malfunction	Troubleshooting
When motor does not excite	Check the connection status between controller and driver and pulse input specifications (voltage, width). Check the pulse and direction signal are connected correctly.
When motor rotates to the opposite direction of the designated direction	When the driver's RUN mode is 1-pulse input method, CCW input [H] is for forward, [L] is for backward. When the driver's RUN mode is 2-pulse input method, check CW and CCW pulse input are changed.
When motor drives unstable	Check the driver and motor are connected correctly. Check the driver pulse input specifications (voltage, width).

Ordering Information

This is only for reference, the actual product does not support all combinations. For selecting the specified model, follow the Autonics website.

MD ① - ② ③ ④

- ① Motor phase: 5: 5-phase
- ② Step method (resolution): H: Micro step (250-division)
- ③ Power supply: F: 100 - 220 VAC
- ④ RUN current: 28: 2.8 A / Phase

Unit Descriptions

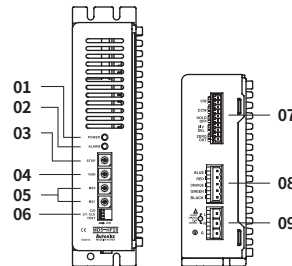

- 01. Power indicator
- 02. Alarm indicator
- 03. Stop current setting rotary switch
- 04. RUN current setting rotary switch
- 05. Resolution setting rotary switch
- 06. Function selection DIP switch
- 07. Input terminal
- 08. Motor terminal
- 09. Power terminal

Connections

- In case of standard wiring type, refer to installation method on 5-phase stepper motor.

