

4 axis Board Type Motion Controller

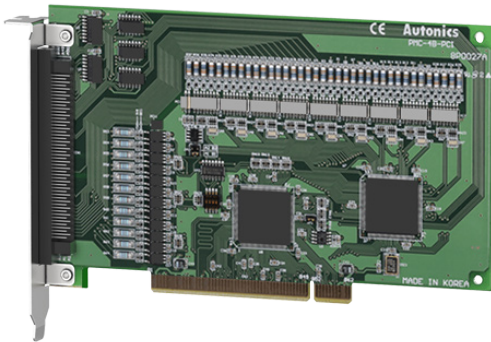

PMC-4B-PCI Series PRODUCT MANUAL

For your safety, read and follow the considerations written in the instruction manual, other manuals and Autonics website.

The specifications, dimensions, etc. are subject to change without notice for product improvement. Some models may be discontinued without notice.

Features

- Independent 4-axis control of AC servo motors and stepper motors
- PC-PCI card type
- Auto home search function and synchronous operation
- Interpolation control for circular, linear, bit pattern, continuous, acceleration, and deceleration drives.
- 2-axis/3-axis constant linear velocity
- Supports Windows 98, NT, 2000, XP, Windows 7
- Labview library and help, and C language library and samples available on www.autonics.com

Safety Considerations

- Observe all 'Safety Considerations' for safe and proper operation to avoid hazards.
- ⚠ symbol indicates caution due to special circumstances in which hazards may occur.

⚠ Warning Failure to follow instructions may result in serious injury or death.

- 01. Fail-safe device must be installed when using the unit with machinery that may cause serious injury or substantial economic loss. (e.g. nuclear power control, medical equipment, ships, vehicles, railways, aircraft, combustion apparatus, safety equipment, crime / disaster prevention devices, etc.)**
Failure to follow this instruction may result in personal injury, economic loss or fire.
- 02. Do not use the unit in the place where flammable / explosive / corrosive gas, high humidity, direct sunlight, radiant heat, vibration, impact or salinity may be present.**
Failure to follow this instruction may result in explosion or fire.
- 03. Do not connect, repair, or inspect the unit while connected to a power source.**
Failure to follow this instruction may result in fire.
- 04. Check 'Connections' before wiring.**
Failure to follow this instruction may result in fire.
- 05. Do not disassemble or modify the unit.**
Failure to follow this instruction may result in fire.
- 06. Do not cut off power or disconnect connectors while operating the unit.**
Failure to follow this instruction may result in personal injury or economic loss.
- 07. Install the safety device at the out of the controller for stable system operation against external power error, controller malfunction, etc.**
Failure to follow this instruction may result in personal injury or economic loss.
- 08. Mount this unit on the PCI bus connector.**
Failure to follow this instruction may result in personal injury, fire or product damage.

⚠ Caution Failure to follow instructions may result in injury or product damage.

- 01. Use the unit within the rated specifications.**
Failure to follow this instruction may result in fire or product damage.
- 02. Use a dry cloth to clean the unit, and do not use water or organic solvent.**
Failure to follow this instruction may result in fire.
- 03. Keep the product away from metal chip, dust, and wire residue which flow into the unit.**
Failure to follow this instruction may result in fire or product damage.
- 04. If a ribbon cable is used as the I/O line, connect the cable correctly and prevent from poor contact.**
Failure to follow this instruction may result in malfunction.
- 05. Note that this device is KCC certified for commercial use. Make proper applications for the product.**

Cautions during Use

- Follow instructions in 'Cautions during Use'.
Otherwise, it may cause unexpected accidents.
- Power supply should be insulated and limited voltage/current or Class2, SELV power supply device.
- Install a power switch or circuit breaker in the easily accessible place for supplying or disconnecting the power.
- Wire as short as possible and keep away from high voltage lines or power lines, to prevent surge and inductive noise.
- Run the unit after setting parameter with proper value depending on the load and environment.
- This unit may be used in the following environments.
 - Indoors (in the environment condition rated in 'Specifications')
 - Altitude max. 2,000 m
 - Pollution degree 2
 - Installation category II

Manual

For proper use of the product, refer to the manuals and be sure to follow the safety considerations in the manuals.

Download the manuals from the Autonics website.

Software

Download the installation file and the manuals from the Autonics website.

■ atMotion

The program allows to manage the motor driver's parameter setting and monitoring data.

Product Components

- Product
- Instruction manual

Dimensions

- Unit: mm, For the detailed drawings, follow the Autonics website.

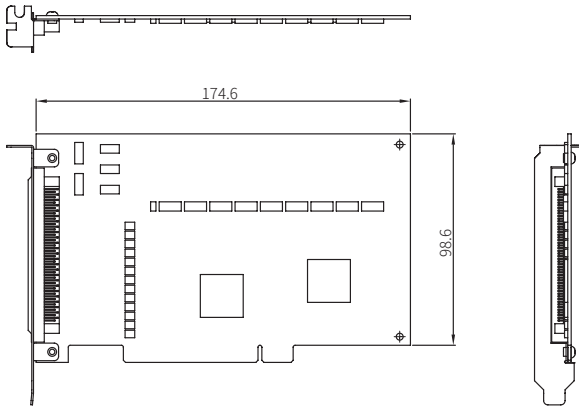

Specifications

Model	PMC-4B-PCI
Power supply	5 VDC \pm 10% (using PC internal power)
External power supply	12 - 24 VDC \pm 10%
Control axes	4 axis
CPU data bus	8 / 16 bit selection
Ambient temp.	0 to 45°C, storage: -10 to 55°C (no freezing or condensation)
Ambient humi.	35 to 85%RH, storage: 35 to 85%RH (no freezing or condensation)
Approval	CE UK ENEC
Unit weight (packaged)	\approx 100.4 g (\approx 654.4 g)
2/3 axis linear interpolation range	-2,147,483,648 to +2,147,483,647 for each axis
2/3 axis linear interpolation speed	1 pps to 4 Mpps
2/3 axis linear interpolation position accuracy	\leq \pm 0.5 LBS (within all interpolation range)
2/3 axis bit pattern interpolation speed	1 pps to 4 Mpps (depending on CPU data setup time)
Circular interpolation range	-2,147,483,648 to +2,147,483,647 for each axis
Circular interpolation speed	1 pps to 4 Mpps
Circular interpolation position accuracy	\leq \pm 1 LBS (within all interpolation range)
Other interpolation function	Select specific axis, constant linear velocity, continuous interpolation step transmission (command, external signal)
Encoder input pulse	2-phase pulse / up down pulse input, 2-phase pulse 1 / 2 / 4-multiply selection
Logic pos. counter range	-2,147,483,648 to +2,147,483,647 (for output pulse)
Actual pos. counter range	-2,147,483,648 to +2,147,483,647 (for input pulse)
Compare register	Comp. \pm register pos. comparison range: -2,147,483,648 to +2,147,483,647 Output and signal output when the current counter value and the user position counter are same Software limit operation
Auto home search	High speed near home search (step1) \rightarrow Low speed near home search (step2)
Interrupt function (except interpolation)	1 drive pulse output: when changing position counter \geq Comp.-, when changing position counter \geq Comp.+, when changing position counter $<$ Comp.-, when changing position counter $<$ Comp.+, when starting constant speed in accel/decel drive, when ending constant speed in accel/decel drive, when ending drive auto home search, when ending auto home search, when running synchronous operation
Drive control by external signal	\pm direction fixed/continuous pulse drive by EXP+, EXP- signal 2-phase encoder signal mode (encoder input) drive
External deceleration stop / immediate stop signal	IN 0 to 3 each axis 4 point Select signal valid/invalid and logic level selection, use general input
Servo motor input signal	Select alarm, INPOS signal valid/invalid and logic level
General output signal	OUT4 to 7 each axis 4 point (both drive status output signal and terminal)
Drive status signal output	ASND (while acceleration), DSND (while deceleration)
Overrun limit signal input	Select +direction, -direction each 1 point and logic level Select stop/deceleration stop at active
Emergency stop signal input	EMG 1 point, stop drive pulse for all axes by low level
Integral filter	Built-in integral filter at each input signal input terminal, pass time (8 type) selection
Others	Select specific axis, constant linear velocity, continuous interpolation, interpolation step transmission (command, external signal)

Drive pulse output (X, Y axis common)	
Output speed range	1 pps to 4 Mpps
Output speed accuracy	\leq \pm 0.1% (for setting value)
Speed magnification	1 to 500
Jerk speed	954 to 62.5×10^6 pps / sec (magnification = 1)
Accel/Decel increase rate	477×10^3 to 31.25×10^7 pps/sec (magnification = 500)
Accel/Deceleration	125 to 1×10^6 pps / sec (magnification = 1) 62.5×10^3 to 500×10^7 pps / sec (magnification = 500)
Initial velocity	1 to 8,000 pps (magnification = 1) 500 to 4×10^7 pps (magnification = 500)
Drive speed	1 to 8,000 pps (magnification = 1) 500 to 4×10^7 pps (magnification = 500)
No. of output pulse	0 to 4,294,967,295 (fixed pulse drive)
Speed curve	Constant speed, Symmetric/Asymmetric linear accel/deceleration, parabola S curve drive
Fixed pulse drive deceleration mode	Auto deceleration (asymmetric linear Accel/Deceleration) / Manual deceleration
Others	Changing output pulse, drive speed while driving Select individual 2 pulse / 1 pulse direction method Select drive pulse logic level Changing output terminal

Connection Diagrams

■ Drive pulse output signal (nP+P/N, nP-P/N)

Drive pulse output generates drive pulse signal of +/- direction using line driver (AM26c31) of differential output.

It is recommended to use twisted pair shield wire for pulse output signal of driver operation regarding EMC.

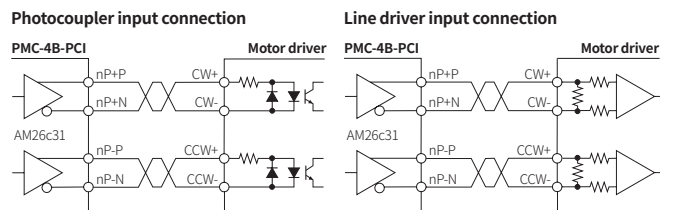

■ General output signal (nOUT4 to 7)

Output signal is output by buffer (74LS06), and all outputs are OFF after reset.

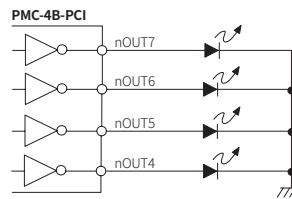

■ Input signal (nIN1 to 3, nINPOS, nALARM, nEXP+/-, EMG)

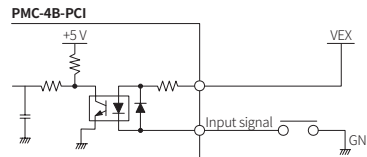

■ Encoder input signal (nECAP/N, nECBP/N) and input signal (nIN0+/-)

Encoder differential output line driver connection

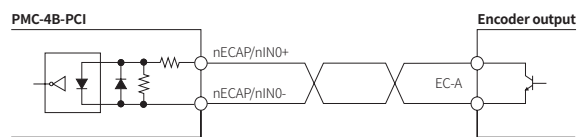

Encoder NPN open collector output connection

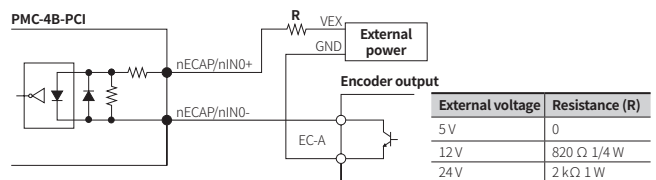

■ Limit input signal (nLMIT+/-)

In general, the limit signal is vulnerable to noise because external exposure of wiring is inevitable. Since it is impossible to remove noise with only a photo coupler, a filter circuit is built into the PMC-4B-PCI. So set an appropriate pass time (FL = 2, 3).

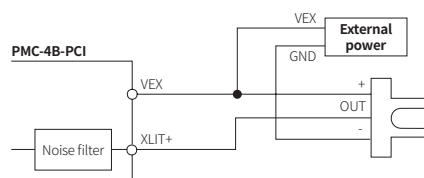

System

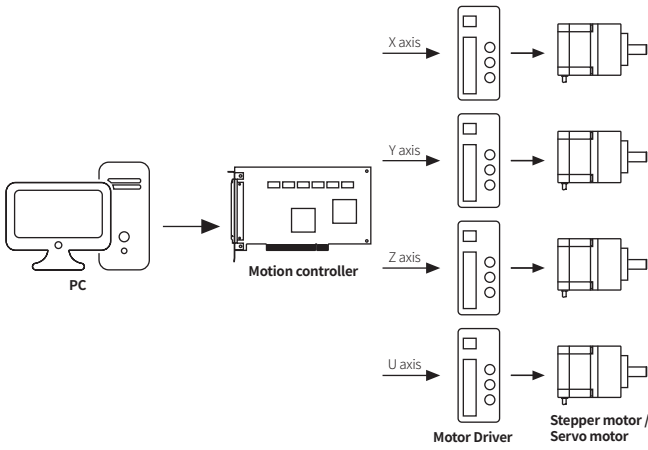

I/O Connections

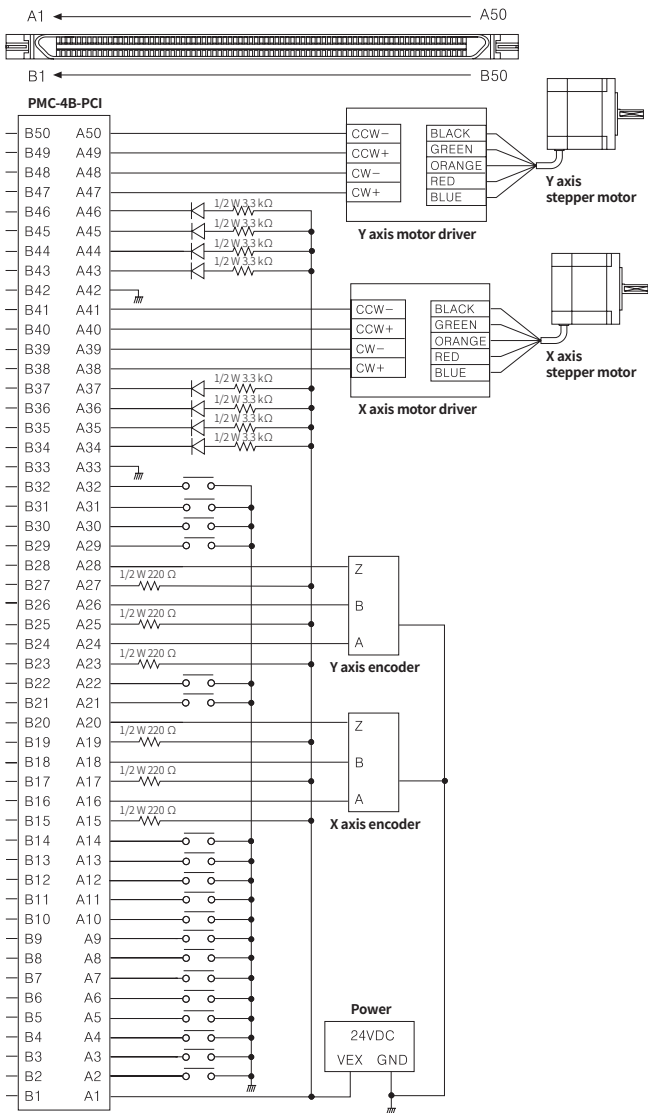

- Diode specification for general output pin should be over 50 V / 1 A.
- Use NPN open collector output (+12 VDC≐) for encoder.
- Following diagram only displayed A side 50 pins, and B side 50 pins are same as A side. But B2 terminal is not for use.

I/O Specifications

Pin	Signal	Description	Pin	Signal	Description
A1	VEX	12 - 24VDC≐	B1	VEX	12 - 24VDC≐
A2	EMG	Emergency stop (4 axis stop)	B2	-	N.C
A3	XLMIT+	X axis + direction limit	B3	ZLMIT+	Z axis + direction limit
A4	XLMIT-	X axis - direction limit	B4	ZLMIT-	Z axis - direction limit
A5	XIN1	X axis input signal (home signal)	B5	ZIN1	Z axis input signal (home signal)
A6	XIN0	X axis input signal (near home signal)	B6	ZIN0	Z axis input signal (near home signal)
A7	XIN3	X axis input signal (encoder Z phase signal)	B7	ZIN3	Z axis input signal (encoder Z phase signal)
A8	YLMIT+	Y axis + direction limit	B8	ULMIT+	U axis + direction limit
A9	YLMIT-	Y axis - direction limit	B9	ULMIT-	U axis - direction limit
A10	YIN1	Y axis input signal (home signal)	B10	UIN1	U axis input signal (home signal)
A11	YIN0	Y axis input signal (near home signal)	B11	UIN0	U axis input signal (near home signal)
A12	YIN3	Y axis input signal (encoder Z phase signal)	B12	UIN3	U axis input signal (encoder Z phase signal)
A13	XINPOS	X axis In-Position input	B13	ZINPOS	Z axis In-Position input
A14	XALARM	X axis alarm input	B14	ZALARM	Z axis alarm input
A15	XECAP	X axis encoder A phase+	B15	ZECAP	Z axis encoder A phase+
A16	XECAN	X axis encoder A phase-	B16	ZECAN	Z axis encoder A phase-
A17	XECBP	X axis encoder B phase+	B17	ZECBP	Z axis encoder B phase+
A18	XECBN	X axis encoder B phase-	B18	ZECBN	Z axis encoder B phase-
A19	XECZP	X axis encoder Z phase+	B19	ZECZP	Z axis encoder Z phase+
A20	XECZN	X axis encoder Z phase-	B20	ZECZN	Z axis encoder Z phase-
A21	YINPOS	Y axis In-Position input	B21	UINPOS	U axis In-Position input
A22	YALARM	Y axis alarm input	B22	UALARM	U axis alarm input
A23	YECAP	Y axis encoder A phase+	B23	UECAP	U axis encoder A phase+
A24	YECAN	Y axis encoder A phase-	B24	UECAN	U axis encoder A phase-
A25	YECBP	Y axis encoder B phase+	B25	UECBP	U axis encoder B phase+
A26	YECBN	Y axis encoder B phase-	B26	UECBN	U axis encoder B phase-
A27	YECZP	Y axis encoder Z phase+	B27	UECZP	U axis encoder Z phase+
A28	YECZN	Y axis encoder Z phase-	B28	UECZN	U axis encoder Z phase-
A29	XEXP+	X axis manual + drive	B29	ZEXP+	Z axis manual + drive
A30	XEXP-	X axis manual - drive	B30	ZEXP-	Z axis manual - drive
A31	YEXP+	Y axis manual + drive	B31	UEXP+	U axis manual + drive
A32	YEXP-	Y axis manual - drive	B32	UEXP-	U axis manual - drive
A33	GND	GND	B33	GND	GND
A34	XOUT4/CMPP	X axis general output	B34	ZOUT4/CMPP	Z axis general output
A35	XOUT5/CMPM	X axis general output	B35	ZOUT5/CMPM	Z axis general output
A36	XOUT6/ASND	X axis general output	B36	ZOUT6/ASND	Z axis general output
A37	XOUT7/DSND	X axis general output	B37	ZOUT7/DSND	Z axis general output
A38	XP+P	X axis +direction +drive signal output	B38	ZP+P	Z axis +direction +drive signal output
A39	XP+N	X axis +direction -drive signal output	B39	ZP+N	Z axis +direction -drive signal output
A40	XP-P	X axis -direction +drive signal output	B40	ZP-P	Z axis -direction +drive signal output
A41	XP-N	X axis -direction -drive signal output	B41	ZP-N	Z axis -direction -drive signal output
A42	GND	GND	B42	GND	GND
A43	YOUT4/CMPP	Y axis general output	B43	UOUT4/CMPP	U axis general output
A44	YOUT5/CMPM	Y axis general output	B44	UOUT5/CMPM	U axis general output
A45	YOUT6/ASND	Y axis general output	B45	UOUT6/ASND	U axis general output
A46	YOUT7/DSND	Y axis general output	B46	UOUT7/DSND	U axis general output
A47	YP+P	Y axis +direction +drive signal output	B47	UP+P	U axis +direction +drive signal output
A48	YP+N	Y axis +direction -drive signal output	B48	UP+N	U axis +direction -drive signal output
A49	YP-P	Y axis -direction +drive signal output	B49	UP-P	U axis -direction +drive signal output
A50	YP-N	Y axis -direction -drive signal output	B50	UP-N	U axis -direction -drive signal output

Ordering Information

This is only for reference, the actual product does not support all combinations. For selecting the specified model, follow the Autonics website.

PMC	-	1	-	2
-----	---	---	---	---

1 Axis / Type
4B: 4-axis board type

2 Connection
PCI: PCI